



D/F MACHINE SPECIALTIES, INC.

MIG & TIG Welding Products, Consumables & Accessories

1750 Howard Drive, North Mankato, MN 56003

Phone: (507) 625-6200 Fax: (507) 625-6203

Email: sales@dfmachinespecialties.com

www.dfmachinespecialties.com

MECHANIZED AND ROBOTIC WELDING

AIR-COOLED MACHINE BARRELS

SERIES 500 - MODEL MAC MIG/MAT MIG

MAC - MACHINE AIR COLLET
(Slip-In Current Tip)

MAT - MACHINE AIR THREADED
(Threaded Current Tip)



INSTRUCTION, PARTS & SPECIFICATIONS MANUAL

D/F MACHINE SPECIALTIES is a world leader in the design, development, and manufacture of “MIG” (GMAW) & “TIG” (GTAW) welding products, consumables and accessories. D/F offers several types of manual Air or Water-Cooled “MIG” welding tools, and with the increased use of automated and robotic welding systems, a demand has been created for welding tools of the highest quality, durability and interchangeability. For over forty years, D/F welding products have been used extensively on “MIG” and “TIG” welding applications. This experience, coupled with patented design features, unavailable on any other competitive equipment, has made D/F welding tools the most advanced “MIG” and “TIG” welding guns and barrels for semi-automatic, automatic or robotic welding applications.

This Catalog is a guide to helping you select the proper tool for a given semi-automatic, automatic or robotic welding application. The following is only a partial listing of available semi-automatic, automatic and robotic guns. For further information on special “MIG” and “TIG” requirements, please consult the factory.

Customer satisfaction and customer benefits are the center points of all strategic contents

The spirit of the D/F Machine Specialties personnel is to listen to and to integrate the customer throughout the process, to develop and design marketable products, to present prototypes, to carry out pilot tests and to prepare for and be open to new technology and tasks. We attract and carefully select talented individuals who share our values. Together we will nurture and sustain a work environment with two-way communication, training, mentoring, and rewarding career opportunities.

Innovation and quality

Innovation and quality come from being receptive and willing to learn from others. We encourage our people to be creative and take risks in the pursuit of excellence. Innovative practices are deeply rooted in every one of our employees, a philosophy that leads to continuous product development and industry firsts.

Progress

By remaining confident, focused, and persistent in challenging times, we will discover opportunity. Commitment to quality and the pursuit on innovation ensure that D/F Machine Specialties will remain an industry leader for years to come.

Commitment to excellence

At D/F Machine Specialties we commit to design, build and deliver premium products and superior customer support to quality driven welding professionals. Customers still to this day choose D/F over competitors because of our responsiveness and flexibility. Customers will continue to choose D/F tomorrow for our superior hand-made products and service. To ensure this, we need creative and competent personnel in all business divisions, an intensive exchange of thoughts and ideas with all users, participation in working and study groups within the field of welding technology and intensive cooperation with institutes and universities.

Teamwork

Striving for excellence is a commitment that is an integral component of the D/F Culture. Our team of skilled and dedicated employees takes pride in the excellence products they produce. Each of us willingly accepts personal responsibility for meeting our commitments and we hold each other to a high standard of accountability.

Responsibility

We will continually strive to be environmentally responsible and to support the health and safety of our employees, customers, and neighbors. We continue to support the communities in which we operate and the industries in which we participate.

Thank You for Choosing D/F Machine Specialties



TABLE OF CONTENTS

Safety	4-6
Introduction, Model Specifications, Disassembly & Assembly	7
Required Tools List for Disassembly & Assembly.....	8-9
(Table 1) Spare Parts, (Table 2) Current Tips, (Table 3) Gas Nozzles.....	10
Models MAC MIG/MAT MIG - Parts	11
Ordering Information, (Table 3) Casings, (Table 4) Liners.....	12
Utility Station.....	13
Torch Holding Rack & Mount.....	14
Mounting Arms & Brackets	15
Wire Feeder Adapters & Inlets.....	16
Torch Connection Options	17
What is the Proper Use of the Nozzle Thread Chaser Tap?.....	18
How Do I Cut, Fit, and Install a New Liner?.....	19
Troubleshooting.....	20-23

BE SURE THIS SAFETY GUIDE REACHES THE OPERATOR

SAFETY MEASURES - **PLEASE READ!**

Welding is not particularly hazardous when certain safety practices are followed. Anyone using this equipment should be thoroughly trained in safe welding practices. Failure to observe safe practices may cause serious injury. Handling welding torches presents no danger if the appropriate safety regulations are strictly adhered to.



WARNING

Protect yourself and others from injury. Serious injury or death may result if welding equipment is not properly installed. Read, follow, understand and save this entire manual and follow your employer's safety practices before installing, operating, or servicing the equipment. Only qualified individuals should install, operate, maintain and repair the equipment.



Please examine carton and equipment for damage immediately upon receipt. Check the equipment against the invoice to make sure it is complete and inspect for damage due to shipping. If there is any damage, please contact the carrier immediately to file a claim. Contact D/F with the information regarding damage claim made to the carrier or shipping errors. Please include a full description of the damage or parts in error.

Electric shock can cause injury or death.

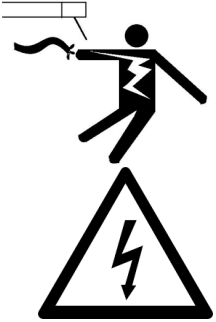

- Wear dry, hole-free insulated gloves and body protection that is in good condition.
- Do not touch electrode with bare hands.
- Do not touch live electric parts.
- Always insulate yourself from the work and ground using insulating mats large enough to cover your full work area.
- Use AC output ONLY if it is required for the welding process.
- Disconnect power before working on the machine.
- Frequently check power cord and ground connector for any damage.
- Replace immediately if any damage is present.
- Properly install and operate all equipment according to the Instruction Manual and all national, state, and local codes.
- Turn off all equipment when not in use.

Smoke, Fumes and Gases can be hazardous to your health.



- Keep your head out of the fumes. Do not breathe the fumes.
- Ventilation must be adequate to remove smoke, fumes and gases during operation.
- If ventilation is poor, wear an approved air-supplied respirator.
- Read and understand the Safety Data Sheets (SDS) and the manufacturers instructions for adhesives, cleaners, coatings, coolants, consumables, degreasers, fluxes and metals.
- Be sure breathing air is safe.
- Remove all degreasing, cleaning, spraying materials from the area.

Arc rays and sparks can burn eyes and skin.



- Always wear an approved welding helmet fitted with the proper shade of filter lenses. A number 12 to 14 shade will provide the best protection.
- Wear safety glasses with side shields under your welding helmet.
- Wear protective clothing made from flame resistant material to protect yourself from the arc rays and sparks.
- Protect other individuals with screens or barriers. Warn others not to watch arc without protective shade.



Welding and Cutting sparks can cause fire or explosion.

- Remove all flammable materials within 35 ft (11m) of the welding or cutting arc. If this is not possible, cover them tightly with approved covers.
 - Always have a fire extinguisher and a trained fire watcher nearby.
 - Do not weld or cut containers that have once held combustibles.
 - Never use oxygen in a welding torch. Only use inert gases or inert gas mixes that are required for the process.
 - Do not weld or cut where the atmosphere may contain flammable dust, gas or liquid vapors.
 - After work is completed inspect the area for sparks, glowing embers and flames.
 - Protect yourself and others from flying sparks and hot metal.
 - Sparks and spatter are thrown from the arc. Always have protective, oil free, flame resistant clothing.
-



Cylinders can explode if damaged.

- Compressed gas cylinders contain gas under high pressure. If the cylinder is damaged it can explode.
 - Use only the correct shielding gas for the process used. Use the right equipment, correct procedures
 - Keep cylinders away from arc welding, cutting or electrical circuits.
 - Never drape a welding or cutting gun over gas cylinder.
 - Install cylinders in an upright position by securing them to a stationary support or cylinder rack.
 - Protect cylinders from excessive heat, arc welding or cutting, electrical circuits, sources of heat, sparks, or flame, and areas where they may be damaged.
 - Keep protective valve caps in place and hand tight when not in use. Always store empty cylinders with valve caps in place
 - Never face valve outlet when opening cylinder valve. Do not stand in front of or behind the regulator when opening the valve.
 - Store compressed gas and oxygen cylinders in separate locations.
-

Noise can damage hearing



- Noise from the welding process can damage hearing
 - Wear approved hearing devices to ensure protection. Hearing protection must be worn by operators and surrounding personnel.
-



Hot parts can burn

- Do not touch hot welded or cut parts bare handed.
 - If handling is needed, use proper tools and personal protection.
 - Allow cooling period before working on or handling parts.
-

Electric and Magnetic fields (EMF) can affect implanted medical devices.



- Persons with implanted medical devices should consult their physician and the device manufacturer prior to going near welding, cutting or induction heating operations.
- EMF fields may interfere with some pacemakers.



Warning:

This product, when used for welding or cutting, produces fumes or gases which contain chemicals known to the State of California to cause birth defects and, in some cases, cancer.

(California Health and Safety Code Section 25249.5 et seq.)

This product contains or produces a chemical known to the State of California to cause cancer and birth defects (or other reproductive harm).

(California Health and Safety Code Section 25249.5 et seq.).

For more information go to www.P65Warnings.ca.gov.

Safety and Operating References

Refer to the following standards in their latest revisions and comply as applicable.

- ANSI Standard Z49.1, SAFETY IN WELDING AND CUTTING obtainable from the American Welding Society, 2501 N.W. 7th St., Miami, FL 33125.
- ANSI Standard Z41.1, STANDARD FOR MEN'S SAFETY - TOE FOOTWEAR obtainable from the American National Standards Institute, 1430 Broadway, New York, NY 10018.
- ANSI Standard Z49.2, FIRE PREVENTION IN THE USE OF CUTTING AND WELDING PROCESSES obtainable from the American National Standards Institute, 1430 Broadway, New York, NY 10018.
- ANSI Standard Z88.2, "Practice for Respiratory Protection" obtainable from the American National Standards Institute, 1430 Broadway, New York, NY 10018.
- ANSI Standard Z87.1, SAFE PRACTICES FOR OCCUPATION AND EDUCATIONAL EYE AND FACE PROTECTION obtainable from the American National Standards Institute, 1430 Broadway, New York, NY, 10018.
- American Welding Society Standard AWSF4.1 "Recommended Safe Practices for the Preparation for Welding and Cutting of Containers and Piping That Have Held Hazardous Substances", obtainable from the American Welding Society, 2501 N.W. 7th St., Miami, FL 33125.
- AWS Standard A6.0, WELDING AND CUTTING CONTAINERS WHICH HAVE HELD COMBUSTIBLES obtainable from the American Welding Society, 2501 N.W. 7th St., Miami, FL 33125.
- NFPA Standard 70-1978, NATIONAL ELECTRICAL CODE obtainable from the National Fire Protection Association, 470 Atlantic Avenue, Boston, MA 02210.
- NFPA Standard 51B "Fire Prevention in Cutting and Welding Processes" obtainable from the National Fire Protection Association, 470 Atlantic Avenue, Boston, MA 02210.
- NIOSH, SAFETY AND HEALTH IN ARC WELDING AND GAS WELDING AND CUTTING obtainable from the Superintendent of Documents, U.S. Printing Office, Washington, D.C. 20402.
- CSA W117.2 "Safety in Welding, CUTting and Allied Processes." Canadian Standards Association, 178 Rexdale Blvd, Rexdale, ON, Canada M9W 1R3.
- OSHA, SAFETY AND HEALTH STANDARDS, 29CFR 1910, obtainable from the U.S. Government Printing Office, Washington, D.C. 20402.

INTRODUCTION

These Air-Cooled Machine Barrels are readily adaptable to Mechanized or Robotic Welding. They are furnished completely assembled and ready for installation. Both Models have the feature of individual replaceable service connections with a removable cable hose sheath to add to the durability and long life of the barrel assemblies.

For further information or help with D/F Machine Specialties products, please visit our web site at www.dfmachinespecialties.com, or consult the factory at 1-507-625-6200.

MODEL MAC/MAT SPECIFICATIONS

Barrel	Current Capacity	Length	Upper Body Diameter (black)	Lower Body Diameter (white)	Nozzle Body Diameter (chrome)	Weight (approx.)	Recommended Wire Diameter Range
Long	400 amp CO ₂ 275 amp Argon	14.250"	1.625"	1.125"	1.250"	2 lbs.	.030"-1/8" Hard/Cored 3/64"-3/32" AL

DISASSEMBLY

- 1) When repairs are made on the production line, make certain the power source and wire feeder are disconnected from primary power.
- 2) Remove forward gas nozzle. If threads are damaged or clogged up with spatter, use the nozzle thread chaser tap (14610) to recondition the nozzle body.
- 3) Remove the current tip with the wrench provided (12111) by loosening the threaded tip, or by loosening collet for a slip-in tip.
- 4) If the collet/threaded adapter (13205) is to be replaced, proceed as follows. Unscrew the nozzle body. If the insulator threads off with the nozzle body it may be necessary to grip the edge of the insulator (13163) and turn it out. Do not apply excessive pressure to the insulator. The nozzle body insulator (16605) can be removed by sliding it to the rear.
- 5) Remove the adapter by using two 5/8" wrenches, one to hold the jam nut (16202) and the other to unscrew the adapter.
- 6) The casing/liner assembly can be removed and replaced by simply loosening the internal locking screw which is visible through the hole located behind the inner body holding screw.
- 7) By removing the flat head inner body holding screw, the inner body with utilities connected may be pulled from the rear of the body tube.

ASSEMBLY

- 1) If a new power cable is required, proceed as follows. Trim approximately 1" off of the cable covering. Carefully wrap the copper strands with the copper sheet. Slip the wrapped copper cable end into the rear of the inner body cable adapter.
- 2) Securely tighten the socket set screws on the power cable assembly.
- 3) Carefully insert the inner body assembly into the body housing. Make certain that the electrical cable and hot inner body is covered by the protective sheath, rubber boot or heat shrink material. The flat head body holding screw may now be applied.
- 4) Check to make sure that your gun assembly has the right size current tip and liners for wire to be used.
- 5) When installing a new collet be careful not to over-tighten it with the collet wrench. Excessive pressure is not required due to the good gripping action of the collet.
- 6) Current tips and nozzles should be cleaned as frequently as required. A clogged gas nozzle will restrict the flow of shielding gases.
- 7) Check regularly the condition of the service hose and control wire connections leading from the wire feeder and power source.

REQUIRED TOOLS LIST FOR DISASSEMBLY & ASSEMBLY

1. **D/F 12111 Collet/Tip Wrench** - This is the only tool that should ever be used to tighten the collet nut or the tip. Pressure should be 30 lbs., or as snug as hand tightened. Never use another wrench to apply more torque to this wrench.
2. **D/F Nozzle Thread Chaser Taps (Front & Rear)** - This is used to re-tap damaged threads that have been improperly cleaned or cross threaded. Always blow out the nozzle and gas nozzle after changing gas cup or re-tapping. For more information on how to use the nozzle thread chaser tap, use the following link: www.dfmachine.com/taps
3. **3/8" Open Ended Wrench** - This is used on the inner body's gas hose fitting to secure the gas hose to the torch's inner body. A crescent wrench could be used instead, but due to the large size of crescent wrenches, we prefer the smaller size of the open ended wrenches. You never want to use excessive force by using too large of a wrench. You will use the Long 7/16" Open Ended Wrench for the fitting on the gas hose itself while using the 3/8" wrench to steady the inner body at the fitting. (see #4)
4. **Long 7/16" Open Ended Wrench** - This is used to secure the gas hose to the torch's inner body. (see #3)
5. **5/8" Open Ended Wrench**
 - A. This wrench is used to secure the adapter and jam nut that hold the current tip to the inner body. In your left hand hold the inner body, and with your right hand thread up the adapter using the 5/8" Open Ended Wrench until it is tight. Now place the same wrench on the jam nut and snug it up against the inner body. Keeping that wrench on the jam nut and placing it on the table for force, take a second 5/8" Open Ended Wrench, place it on the adapter and push it down (counter-clockwise) securing the adapter to the inner body.
 - B. This is used to secure the nut and washer to hold the power cable lug on the torch's body.
6. **Adjustable Crescent Wrench** - A medium size adjustable crescent wrench could be used as well. **CAUTION:** Never use excessive force with large wrenches, for you could twist or break parts.
7. **Standard Flat Head Screwdriver** - This is used to tighten or secure the torch's body screw. Also, the screwdriver can be used to straighten the contact tip if it is not aligned in the center of the gas cup or water-cooled nozzle **CAUTION:** This cannot be done unless the spatter disc has been removed from the torch.
8. **Long Nose Pliers** - These are very handy when changing a slip-in contact tip.
9. **3/32" Allen Wrench** - This is used to secure the set screw that holds the casing in the torch's inner body.

REQUIRED TOOLS LIST FOR DISASSEMBLY & ASSEMBLY

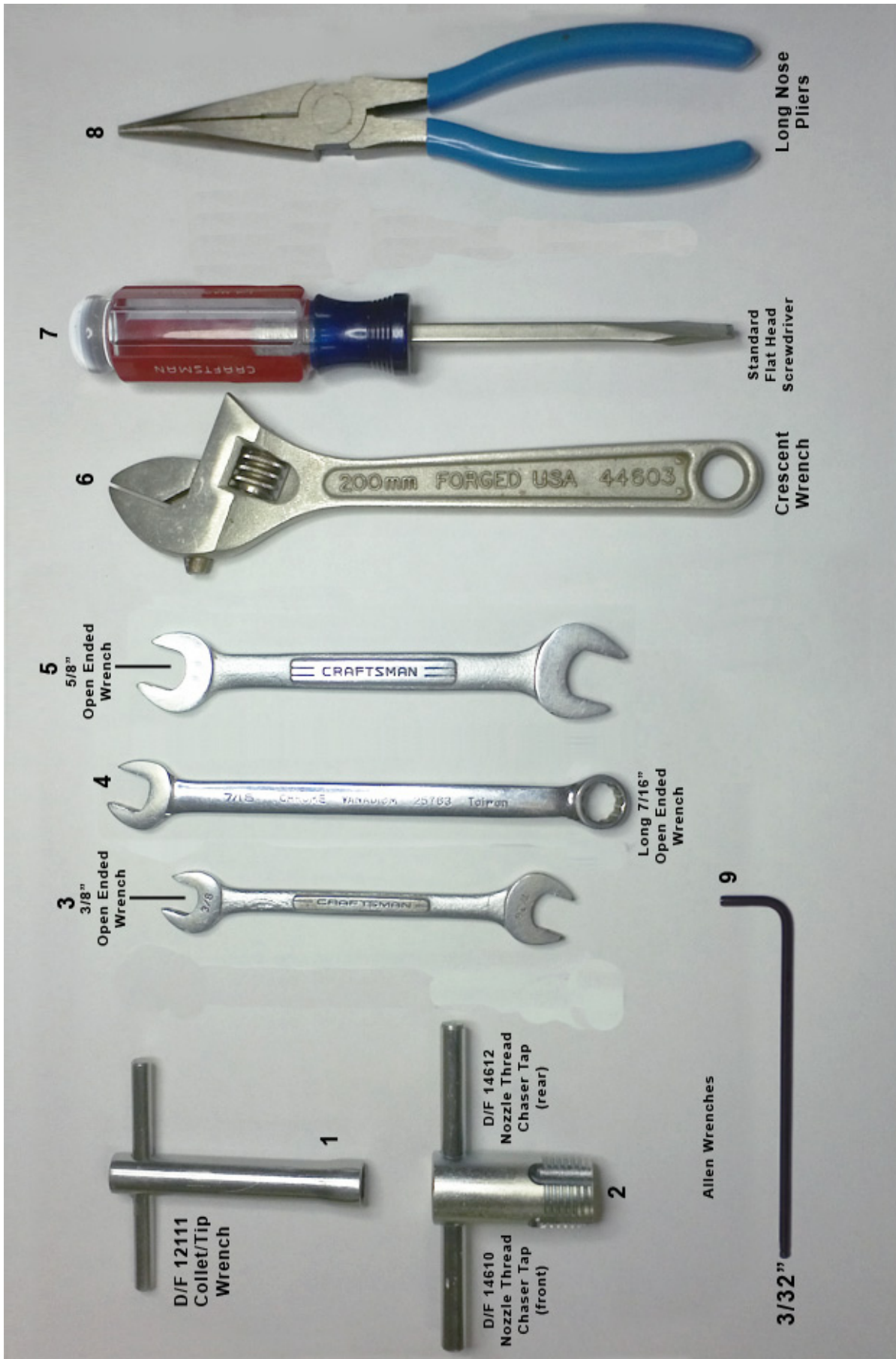

TABLE 1 - GAS NOZZLES

Gun Model	Ref.	Nozzle Type	O.D.	I.D.	Code No.
CCA/CCT	1	Copper Tapered	63/64"	5/8"	10362
	2	Copper Straight	1"	3/4"	10340
	3	Copper Full Taper	63/64"	5/8"	10359
	4	Copper Straight (used with 1/4" tip only)	5/8"	7/16"	10374
	5	Copper Straight (used with 5/16" tip only)	21/32"	1/2"	19348

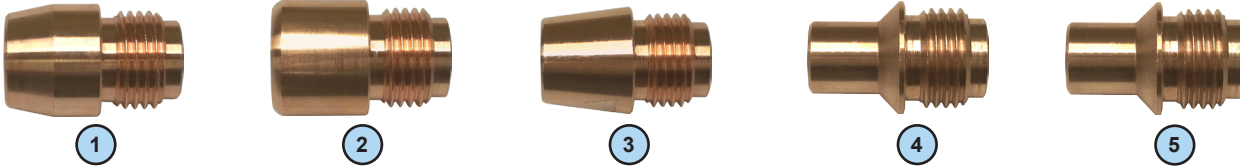
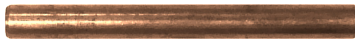

TABLE 2 - CURRENT TIPS

CURRENT TIPS - 2-1/2" SLIP-IN - 1/4" DIAMETER

Gun/Barrel Model	Wire Size	Wire Type	Code No.
All NC, NCC, NCM (Tip provides 1/8" set back)	.030"	Hard	10794
	.035"	Hard	10795
	.045"	Hard	10796
	.052"	Hard	10840
	1/16"	Hard	10797
All NC, NCC, NCM (Tip provides 1/8" set back)	3/64"	Aluminum	10785
	1/16"	Aluminum	10786



CURRENT TIPS - 2-1/2" SLIP-IN - 5/16" DIAMETER

Gun/Barrel Model	Wire Size	Wire Type	Code No.
All NC, NCC, NCM (Tip provides 1/8" set back)	.030"	Hard	19390
	.035"	Hard	19391
	.045"	Hard	19392
	.052"	Hard	19393
	1/16"	Hard	19394
	5/64"	Hard	19711
	3/32"	Hard	19726
	7/64"	Hard	19396
	1/8"	Hard	19727
	All NC, NCC, NCM (Tip provides 3/8" set back)	.035"	Cored
.045"		Cored	19401
.052"		Cored	19402
1/16"		Cored	19403
5/64"		Cored	19404
3/32"		Cored	19405
7/64"		Cored	19406
1/8"		Cored	19720
All NC, NCC, NCM (Tip provides 1/8" set back)	3/64"	Aluminum	19407
	1/16"	Aluminum	19408
	5/64"	Aluminum	19728
	3/32"	Aluminum	19409

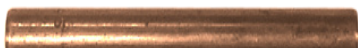

CURRENT TIPS - 7/16" DIAMETER THREADED

Gun/Barrel Model	Wire Size	Wire Type	Code No.
All HT, HTC, HTM, CTW, CW-T, MTW (Tip provides 1/8" set back)	.035"	Hard	15116
	.045"	Hard	15117
	.052"	Hard	15121
	1/16"	Hard	15118
	5/64"	Hard	15119
	3/32"	Hard	15120
	7/64"	Hard	15122
All HT, HTC, HTM, CTW, CW-T, MTW (Tip provides 3/8" set back)	1/8"	Hard	15105
	.035"	Cored	15101
	.045"	Cored	15106
	.052"	Cored	15112
	1/16"	Cored	15107
	5/64"	Cored	15108
	3/32"	Cored	15109
All HT, HTC, HTM, CTW, CW-T, MTW (Tip provides 1/8" set back)	7/64"	Cored	15110
	1/8"	Cored	15111
	3/64"	Aluminum	15126
	1/16"	Aluminum	15125
	5/64"	Aluminum	15087
	3/32"	Aluminum	15148
	1/8"	Aluminum	15123

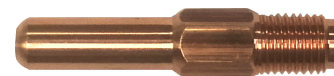

AIR-COOLED ROBOTIC MACHINE BARREL MODEL MAC MIG/MAT MIG

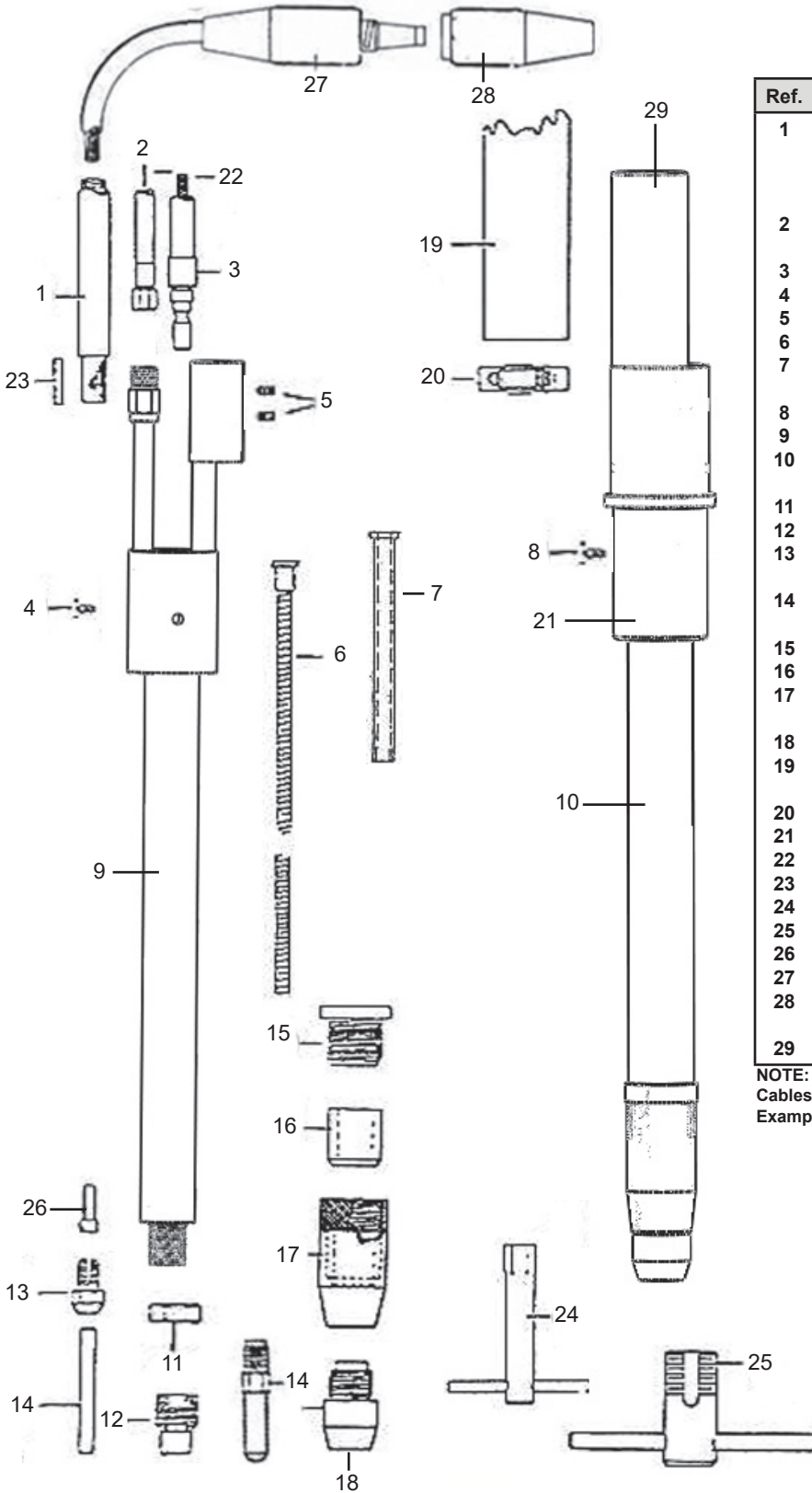

Ref.	Code No.	Description
1	36901-X	Power Cable 1/0 (Used w/Utility Station) (2 Ft. - 15 Ft. must specify length)
	18194-X	Power Cable 1/0 w/ Male Connector (2 Ft. - 15 Ft. must specify length)
2	46259	Gas Hose Assembly (2 Ft. - 15 Ft. must specify length)
3		Casing (p. 12, Table 3)
4	14712	Socket Set Screw
5	12543	Socket Set Screw (2 req'd)
6	36931	Flared Body Liner 5/64"-1/8"
7	36930	Alignment Tube (used with .030"-1/16" steel and 3/64"-3/32" Aluminum)
8	12610	Flat Head Screw
9	36820	Inner Body
10	36826	Insulation Tube - Split - Full Diameter
	36827	Insulation Tube - No Split, Full Diameter
11	16202	Jam Nut
12	13205	Adapter
13	11950	Collet Nut - 1/4" Slip-In Tip
	18262	Collet Nut - 5/16" Slip-In Tip
14		Current Tip Slip-In (p. 10, Table 2)
		Current Tip Threaded (p. 10, Table 2)
15	13163	Threaded Insulator (Brown)
16	16605	Insulator (White)
17	13176	Nozzle Body (With 13163 Insulator)
	13197	Nozzle Body (Less 13163 Insulator)
18		Gas Nozzle (see p. 9, Table 1)
19	46630-X	Cable Hose Protector Sheath (2 Ft. - 15 Ft. must specify length)
20	14803	Clamp
21	36828	Body Housing
22		Liner (see p. 12, Table 4)
23	16196	Cable Clamp Kit
24	12111	Wrench
25	14610	Nozzle Thread Chaser Tap - Front
26	16089	Bushing - used with 1/4" x 2.5" Tip
27	16875	Connector - Male
28	16876	Connector - Female
	16874	Connector- Complete-Male & Female
29	14501	Boot

NOTE: Add Footage To Code No. For Length Required For Power Cables, Gas Hoses & Sheaths

Example: Require 8 Ft. Gas Hose: Code No. 46259-8

RECOMMENDED SPARE PARTS

ITEM	CODE NO.	MIN QTY.
Gas Nozzle	To Be Selected	2
Current Tip	To Be Selected	25
Collet Nut	To Be Selected	1
Body Liner	To Be Selected	2
Insulation Tube	To Be Selected	1
Insulator	13163	1

ORDERING INFORMATION

MODEL MAC/MAT ORDERING INFORMATION

Description	Code and Model No. for Available Lengths							
	4 Ft.	5 Ft.	6 Ft.	7 Ft.	8 Ft.	10 Ft.	12 Ft.	15 Ft.
MAC (Slip-In Tip)	36920-4 Model MAC MIG 500-4	36920-5 Model MAC MIG 500-5	36920-6 Model MAC MIG 500-6	36920-7 Model MAC MIG 500-7	36920-8 Model MAC MIG 500-8	36920-10 Model MAC MIG 500-10	36920-12 Model MAC MIG 500-12	36920-15 Model MAC MIG 500-15
MAT (Threaded Tip)	36930-4 Model MAT MIG 500-4	36930-5 Model MAT MIG 500-5	36930-6 Model MAT MIG 500-6	36930-7 Model MAT MIG 500-7	36930-8 Model MAT MIG 500-8	36930-10 Model MAT MIG 500-10	36930-12 Model MAT MIG 500-12	36930-15 Model MAT MIG 500-15

TABLE 3 - CASINGS

Description	Wire Size	2 Ft.	3 Ft.	4 Ft.	5 Ft.	6 Ft.	7 Ft.	8 Ft.	10 Ft.	12 Ft.	15 Ft.
Casing Assembly (Flexible)											
Select Liner	.030"	14440	14441	14442	14443	12291	12292	12285	12286	12287	12290
Select Liner	.035"-1/16" **	14444	14445	14446	14447	16173	16561	13565	13751	13757	13752
Casing Assembly (Reinforced)											
Single Piece	.035"-.045"	16735	16736	16737	16738	16739	16740	16512	15988	15991	16055
Single Piece	.045"-1/16"	15750	15751	15752	15753	15754	15755	16513	12380	12383	12386
Single Piece	5/64"-3/32"	15729	15730	15731	15732	15733	15734	15735	12441	12449	12443
Single Piece	7/64"-1/8"	15740	15741	15742	15743	15744	15745	16515	12445	12448	12446

** Liners to be used with double asterisk casing

TABLE 4 - LINERS

Description	Wire Size	2 Ft.	3 Ft.	4 Ft.	5 Ft.	6 Ft.	7 Ft.	8 Ft.	10 Ft.	12 Ft.	15 Ft.
Hard	.030"	-	14130	14131	14132	16818	16819	16820	12320	12321	12322
Hard/Cored	.035"-.045" **	16443	16444	16445	16446	16447	16448	16449	16407	16408	16409
Hard/Cored	.045"-1/16" **	16147	16148	16149	16150	16151	16152	16153	16119	16120	16121
Stainless	.035"-.045" **	16154	16155	16156	16157	16158	16159	16160	12336	12337	12338
Stainless	.045"-1/16" **	16501	16502	16503	16504	16505	16506	16507	16508	16509	16510
Aluminum	3/64" **	16833	14146	14148	14150	16618	16619	12410	12411	12412	12413
Aluminum	1/16" **	16834	14152	14154	14156	14164	16620	12401	12402	12416	12404
Aluminum	3/32" **	16835	14158	14160	14162	14165	16769	16602	16602	12417	12426

** Liners to be used with double asterisk casing

UTILITY STATION 45184 - AIR-COOLED BARRELS

ORDERING INFORMATION

Description	Code No.
Utility Station - Air-Cooled Barrels	45184

DIMENSION SPECIFICATIONS

Base Length	3.75"
Overall Length	5.75"
Base Width	2.25"
Overall Width	2.5"
Overall Height	3.125"
Mounting Hole Center Distance	2.75"
Overall Weight	3.5 lbs.

D/F TORCH CONNECTION

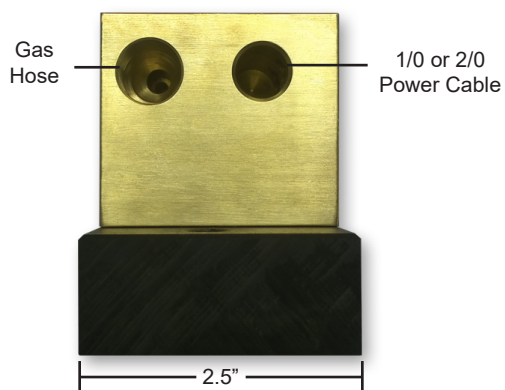

UTILITY STATION SIDE VIEW WITH COVER

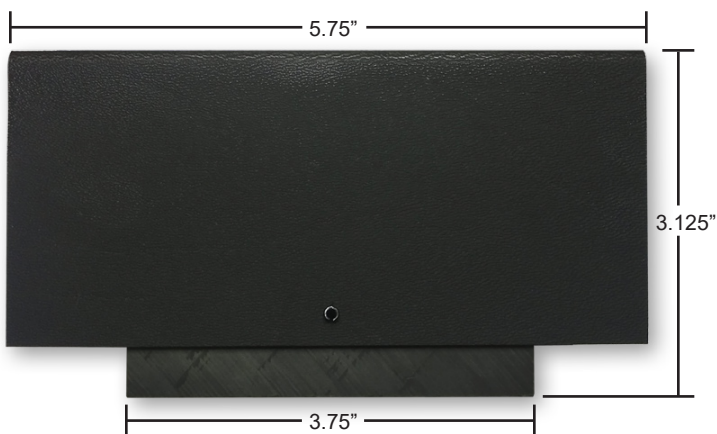

CUSTOMER UTILITIES CONNECTION

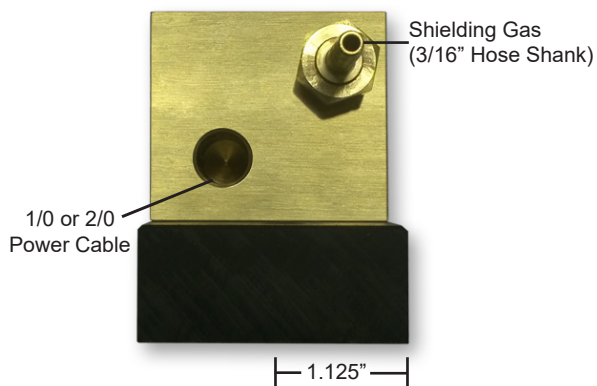

FROM LEFT: D/F TORCH CONNECTION FROM RIGHT: CUSTOMER UTILITIES CONNECTION

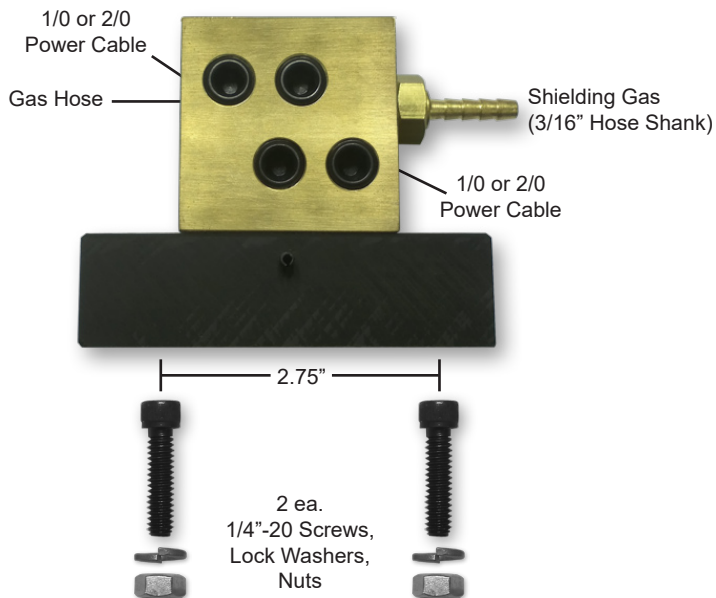

TORCH HOLDING RACK & MOUNT

Ref.	Code No.	Description
1	30418	Rack 6" (32 pitch, 1-3/8" dia.
2	30419	Torch Rack Mount

An optional D/F Torch Rack can be used on any Automatic or Robotic torch with our standard sized assemblies (1.125" diameter). The 6" rack has 32 pitch gear teeth and slips right over the torches white insulation tube, secured with 4 set screws. The rack holder makes vertical torch head positioning very easy giving the user a range of 6" vertical height adjustment

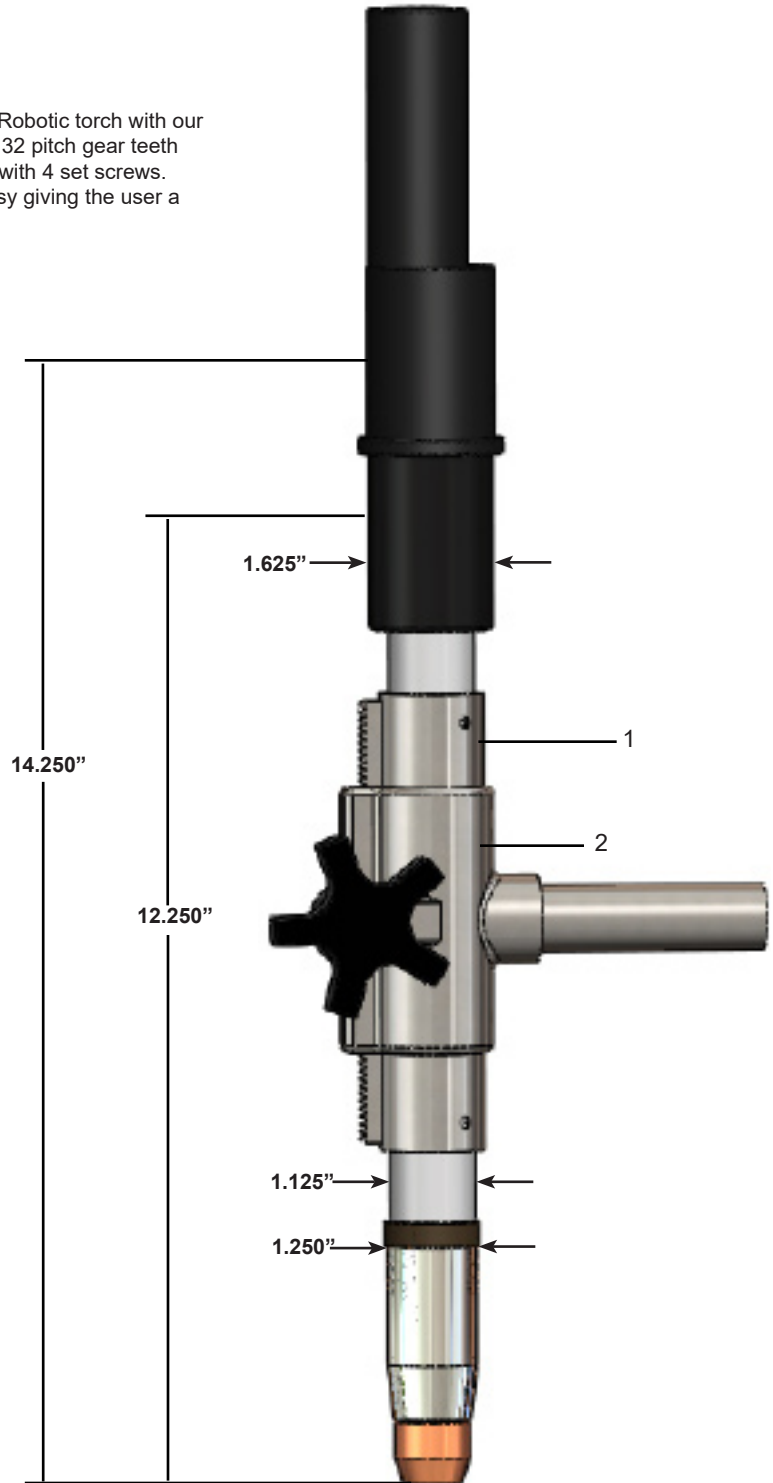

MOUNTING ARMS & BRACKETS

Ref.	Code No.	Description
	40869	Arm Assembly - Complete 6"
	40870	Arm Assembly - Complete 8"
	40871	Arm Assembly - Complete 10"
2	40865	Rear Shaft Bracket Only
3	30196	Bushing for mounting on black body housing (1.625" ID)
	30192	Bushing for mounting on white insulation tube (1.125" ID)
4	40565	Arm - Only 6"
	40566	Arm - Only 8"
	40567	Arm - Only 10"

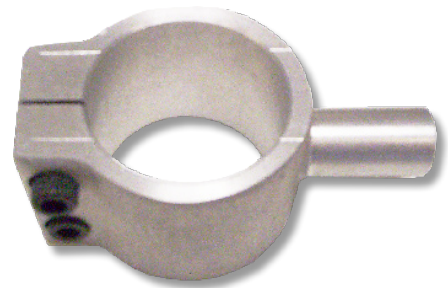

Universal Mounting Arms

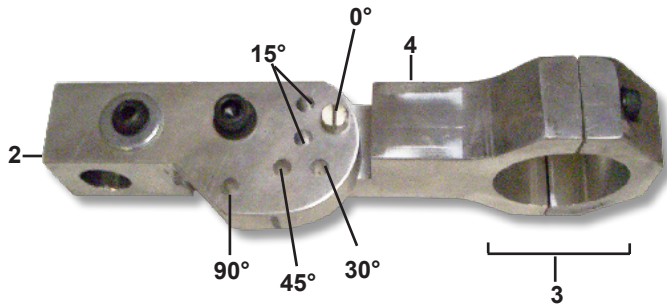

**Mounting Bracket
Code No. 14085**

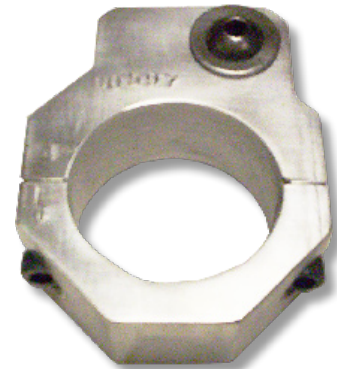

**Mounting Bracket
Code No. 40597**

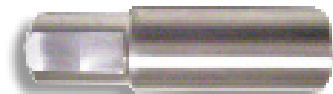
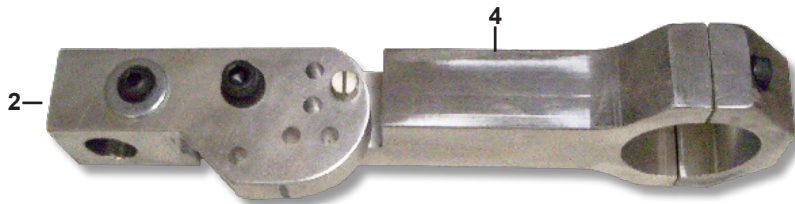

**Torch Bracket Mounting Shaft
Code No. 40598**

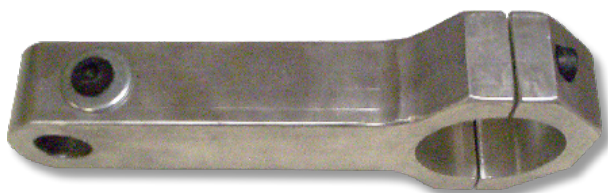
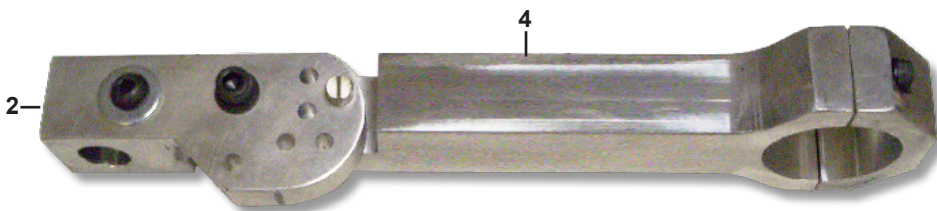

Straight Mounting Arms
Available in various lengths
up to 10" overall
Consult factory for details

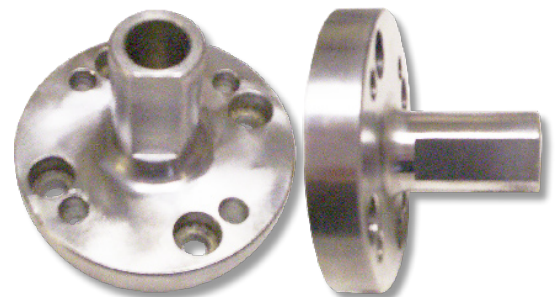

**Flanged Post Mount
Code No. 40589**

WIRE FEEDER ADAPTERS & INLETS

Manufacturer	Models	Wire Diameter	Remote Mount Adapter			Direct Mount Adapter	
			Hard or AL	Cored	Stub* Liner	Hard or AL	Cored
ESAB®	D20 (20mm)	.030"-3/32" H/C/AL 5/64"-1/8" H/C	13098	13099	*	13096	13097
ESAB®			18246	18247		18248	18249
EURO			18493	18493		18540	18540
Hobart®	All Models	.030"-3/32" H/C/AL 5/64"-1/8" H/C	13067	16087	*	13068	16225
Lincoln®	LN-7, LN-8, NA5-R	.030"-3/32" H/C/AL 5/64"-1/8" H/C	13110	13112	*	13113	13116
	LN-9	.030"-3/32" H/C/AL 5/64"-1/8" H/C	16581	16582	*	16528	16529
	NA3, NA5	.030"-3/32" H/C/AL 5/64"-1/8" H/C	16879	16878	*	16880	16881
"BIG MIG"	NA3, NA5	.030"-3/32" H/C/AL 5/64"-1/8" H/C	16879	16878	*	16888	16888
Lincoln®	Power-Feed 10, LF-72, LF-74	.030"-3/32" H/C/AL 5/64"-1/8" H/C	13479		*	13480	
				13469	*		13468
Linde®	SWM31 SWM34 SWM37 SWM38 EH8	Casing to Feeder (Accepts Linde® Outlet Guide)	13046			13046	
		D/F Insert					
		.035"-.045" Hard .045"-1/16" Hard 5/64"-3/32" Cored 3/64"-1/16" AL	13047 13048 13050	13049		13047 13048 13050	13049
	EH10	.030"-3/32" H/C/AL 5/64"-1/8" H/C	13043	13052	*	13080	13079
Mavrix®	PA-10	.030"-3/32" H/C/AL 5/64"-1/8" H/C	16556	16568	Requires Inlet		
Miller® (50 Series)		.030"-3/32" H/C/AL 5/64"-1/8" H/C	16557		*	16558	
				16559	*		16560
OTC®	Requires Insert	.030"-1/8" .030"-1/8"	18268		*		
	CMRE-741		18282			18275	
Panasonic®	PME-12X YW50AKW1	.030"-1/16" .030"-1/16"	13090				
			13466		Requires Inlet		
TWECO®	#4	.030"-3/32" H/C/AL 5/64"-1/8" H/C	13479		*	13480	
				13469	*		13468
Welding Alloys®		.030"-3/32" H/C/AL 5/64"-1/8" H/C			Requires Liner Requires Inlet	13486	13486

*Stub liners only required in feeder adapter when single-piece casing is used.

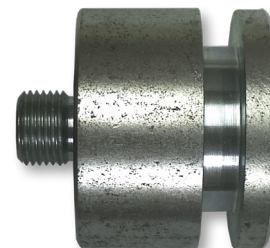
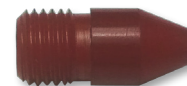
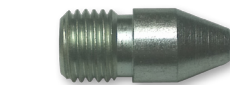
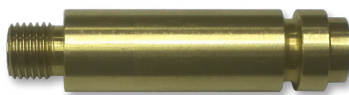

ORDERING INFORMATION

Each D/F gun is fully assembled and ready to install. In order to make the installation complete, the code number, wire size & type, make/model of wire feeder, and inlet as needed must be specified when ordering. If special welding tools or accessories other than those listed previously are required, please consult with the factory.

FEEDER ADAPTER INLETS

Wire Size	Steel Code No.	Brass Code No.	Nylon Code No.
.030"	13801	16417	
.035"	13803	16418	
.045"	13806	16419	
.052"	13844	16420	
1/16"	13809	16421	
5/64"	13812	16422	
3/32"	13814	16422	
7/64"	13816		
1/8"	13842		
3/64" AL			13807
1/16" AL			13810
3/32" AL			13815

Esab®, Hobart®, Lincoln®, Linde®, Miller®, OTC®, Panasonic®, ABB®, Fanuc®, Kuka®, Mavrix®, Motoman®, Thermal Arc®, TWECO®, & Welding Alloys® are registered trademarks of their respective companies. Names are mentioned for reference only. D/F Machine Specialties is in no way affiliated with these companies.

TORCH CONNECTION OPTIONS

BARREL MOUNTING OPTIONS

Typical modern torch setups utilize a unitized cable assembly with the power, gas and liner combined into a single replaceable unit. When damaged, worn out, or an issue occurs, the whole unitized cable assembly must be replaced. This can be expensive as it is not repairable. This approach does not allow for a large enough inner power cable needed for necessary high amperages, and it is restricted in size by small passages for gas and wire. Also, since the liner and wire is inside the "hot" unitized cable assembly, the liner and wire are preheating at the wire feeder, which results in everything prematurely breaking down, reduced consumable life, and welding and feeding issues.

D/F Air-Cooled torches take an alternative approach to the setup. The torches use a separate gas hose, power cable, and casing/conduit. When one cable goes bad it is simply replaced instead of attaching an entire new unitized cable assembly; a huge cost saver! This is also where the D/F Utility Station comes into play. The gas hose, power cable are interfaced with the customer's existing lines via the Air-Cooled Utility Station. The D/F torch leads plug into the front of the Utility Station. Into the back of the Utility Station go the customer's utilities (gas and power). The 4/0 power cable MUST go directly from the power source to the back of the Utility Station. This is how the D/F torches are powered, NOT with a power cable to the wire feeder; there can be no jumper cable from the drive roll to the Utility Station. Remove the 4/0 power cable from the lug of the wire feeder drive roll stand, cut the lug off the power cable, strip the cable back roughly 2", and insert the 4/0 power cable into the back of the D/F Utility Station. Finally, a short gas hose jumper is needed for control of the gas. Remove the small black 3/16" hose that connects from the solenoid to the feeder input inside the wire feeder. The jumper can be attached by removing the 3/16" hose from the solenoid, and attaching the 3/16" gas jumper hose to the solenoid and to the back of the D/F Utility Station's 3/16" shank.

Every welding application is different because of size restrictions, access restrictions, positioning restrictions, etc., D/F manufactures barrels in two variations, remote mount and direct mount.

FIGURE 1 - REMOTE MOUNT/ROBOTIC BARRELS

The D/F wire casing/conduit follows a different route than the power cable and gas line. On remotely mounted guns and barrels (Fig. 2), the casing/conduit comes straight out the top of the barrel as the other hoses do (180 degrees), but attaches straight to the wire feeder with a feeder adapter. D/F refers to power pins as feeder adapters, for on D/F barrel setups there is no power going to the wire feeder. The feeder adapters can hook up to any of the different Miller, Lincoln, Esab, Welding Alloys, Fronius, Tweco, etc. wire feeders. In turn the D/F casing/conduit is not powered. Its only purpose is to support the liner, which protects the casing and supports the wire.

FIGURE 2 - DIRECT MOUNT/AUTOMATIC BARRELS

A directly mounted barrel plugs directly into the wire feeder and hangs from the feeder. In a direct mount barrel the power cable and gas hose come out of the barrel at a 90 degree angle and go to the Utility Station, and there is no casing/conduit. The feeder adapter comes out the top of the barrel and connects directly to the wire feeder.

FIGURE 3 - DIRECT MOUNT BARREL - REMOTELY MOUNTED

A third optional mounting method exists that combines features of direct and remote mounting. A direct mount barrel can be remotely mounted with a mounting arm or bracket, and a casing can be attached to the top of the barrel to run to the wire feeder as a remotely mounted barrel would. This unique solution might work for jobs with very limited space.

These alternative setups utilizing the D/F Utility Station enable the D/F barrels to run cooler, work above 1000 degree pre-heat, increase the weld quality (X-ray quality welds), have increased durability, and run the full range of wire through 1/8". It also allows for many different model options, saves on consumable costs, reduces down-time, and allows for a clean installation and ease in maintenance or replacement. The Utility Station is universal throughout the D/F product line. Every D/F barrel will hook up to the same Air-Cooled #45184 Utility Station.

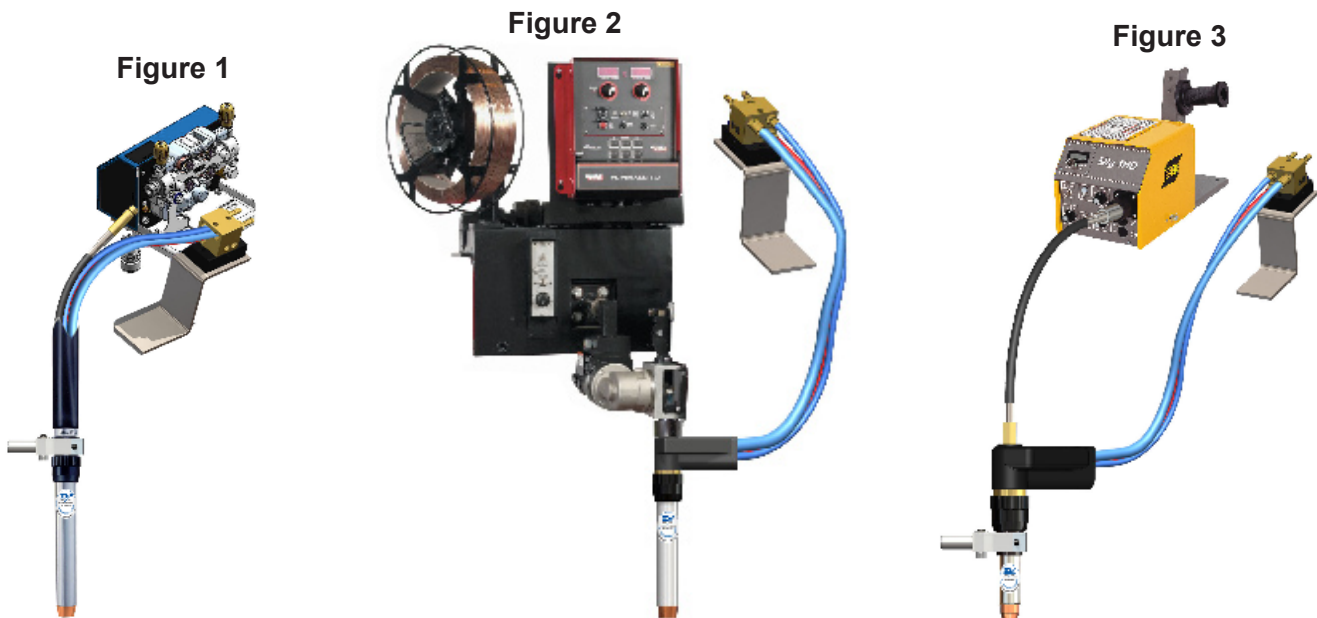

WHAT IS THE PROPER USE OF THE NOZZLE THREAD CHASER TAP?

All D/F Nozzles are hand checked for fit before and after plating, and checked again before shipping. If a nozzle has been installed on a new complete torch, they have also been hand checked while being assembled.

The only reason to ever take a gas cup out a nozzle is to clean it. The nozzle and the gas cup must be blown out, and all of the threads have to be wire brushed and blown out again before hand-tightening the gas cup back into the nozzle. If you can't thread it in by hand then something is wrong. Never force a gas cup into a nozzle.

When using the D/F Machine Specialties nozzle thread chaser taps, be sure to always follow the steps below:

1. Make sure that the nozzle is properly supported when tapping so it does not twist in the front of the torch body and cause damage.
 - Improper support can cause the spigots to twist off the top of the rear nozzle collar, or damage the torch internal body parts.
 - Note where the water ports go down the sides of the water-cooled nozzle (following down in line with the spigots). Too much direct pressure on these water ports could cause them to cave in and block of the flow of water.
 - Best practice is to hold the water-cooled nozzle in a vice with soft jaws, perpendicular to the spigots.
 - Over-tightening of the vice can cause damage in general.
2. Remove the tip from the front of the torch before tapping.
3. Lightly lubricate the nozzle and nozzle thread chaser tap before tapping.
4. Be sure to start the tap very carefully. Do not cross thread the nozzle.
5. Be very careful to start threads correctly. Only tap 1/2 turn at a time, always backing up and removing chips 1/2 cycle at a time before moving forward. Do not try to tap further into the water-cooled nozzle than needed or past the factory thread depth.
6. Blow out the nozzle after tapping. Wire brush and blow off the gas cup before threading it back into the nozzle.
7. If nozzle is badly deformed or damaged please return to the factory for a repair estimate before disposing of product (damaged parts can often be repaired).

ORDERING INFORMATION - NOZZLE THREAD CHASER TAPS

CODE NO.	DESCRIPTION	USED WITH NOZZLE ASSEMBLY	USED FOR GAS NOZZLE
14610	Nozzle Thread Chaser Tap for Standard A/C & W/C Nozzle Assembly Front	13197 16184 11117, 45101 11118, 45102 11119, 45103 45114 45107 NCC-N/HTC-N NCC-LRN, HTC-LRN	10340 10359 10362 10374
14611	Nozzle Thread Chaser Tap for BIG MIG & BIG TIG Nozzle Assembly Front	11123	10382 10387 10389 10390 10392
14614	Nozzle Thread Chaser Tap for Series A High-Capacity Nozzle Assembly Front	11142, 45120 11138, 45121 45127 11132, 45129 45125	16748 16749 16750 16751 18030 18031 18032
14615	Nozzle Thread Chaser Tap for Nozzle Body Assembly Front	13198	10379
14617	Nozzle Thread Chaser Tap for Tandem Nozzle Assembly Front	41641	41667 41668

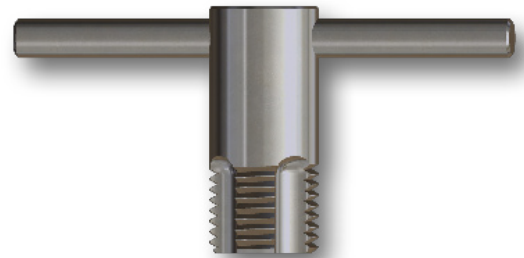

HOW DO I CUT, FIT, AND INSTALL A NEW LINER?

1. Be sure the MIG Gun cable is arranged in a straight line, free from twists, when installing or removing a wire liner.
2. Remove the old liner by first removing the MIG gun's contact tip.
3. Pull the old wire liner out of the conduit/casing assembly from the feeder connector or feeder adapter plug end. If you are using a feeder adapter that has an inlet, the inlet must be removed first. If you have any problems removing the liner you may un-thread the feeder adapter first this will also back the liner out of the conduit/casing.
4. If you know that the old liner is the correct length or is still the original liner that was cut at the factory you may hold the new liner up against the old liner and cut off the new liner to the same size as the old liner.
5. Make sure you have a good sharp cut off with no material sticking out!
6. To get the correct length of the new liner, insert the liner into the feeder adapter and feed it through the conduit/casing.
7. Once again be sure the MIG Gun cable is arranged in a straight line, free from twists, when installing a new wire liner.
8. Sometimes on longer conduits/casings and liners it may take 2 people together; one on each end to rotate and twist the conduit/casing to get the liner through the torch.
9. If you have any troubles getting a liner through a torch make sure you have a good sharp cut off, and if you have to you can gently sand the end of the liner on a belt sander. You can remove the cast in the aluminum liner by pre-bending and straightening the liner before loading.
10. After the new liner comes out the end of the torch you want to cut the new liner off flush with the end of the copper gas nozzle or Cu gas cup.
11. Now you have the overall length of the liner, you still have to take out the length of the contact tip.
12. Carefully remove the liner one more time.
13. After removing the liner hold the gun end of the liner up against the tip.
14. Cut off the length off the tip plus the set back of the tip (1/8" or 3/8" tip setbacks)
15. Now that you have cut off the length of the tip plus the setback you may install the new liner and it will back up into the back of the tip chamfer.
16. We always recommend checking the condition of the insulation tube in the front of the torch and collet nut that holds the slip-in tip.
17. We always recommend replacing the spatter disc/gas diffuser, contact tip, and nozzle, after installing a new liner.
18. Tighten the flat head set screw in the inner body, or the Allen set screw in the docking spool onto the conduit/casing to prevent backward movement or an unwanted pumping action.

TROUBLESHOOTING: GENERAL GUIDE

Problems/Causes

Possible Solutions

ERRATIC WIRE FEED

Slipping feed rolls

Check that the feed roll size is correct for the wire size being used. Increase the drive roll pressure until the wire feed is even. Do not apply excessive pressure as this can damage the wire surface, causing copper coating to loosen from steel wires or metal shavings to be formed from soft wires like aluminum. These metal fragments or shavings can be drawn into the wire feed conduit and will rapidly clog the liner. When welding with flux-cored wires, excessive drive roll pressure may open the wire seam and allow flux or metal powders to escape.

Clogged or worn gun liner

a. Dust, particles of copper, drawing lubricants, metal or flux and other forms of contamination can all clog the liner so that the wire feed is slowed or impeded. A liner that has been in use for an extended period of time becomes worn and filled with dirt and must be replaced.

b. When changing the welding wire, remove the tip from the front end of the gun and blow out the body liner with clean, dry compressed air from the back of the gun. Repeat with the casing and liner assembly. Note: Wear safety goggles when using compressed air to clean the liners. Make sure proper safety procedures are followed in order to avoid possible serious eye injury.

Liners too long or too short

Check the lengths of the liners and trim or replace if too long or too short. The efficient feeding of the welding wire is dependent on the liners fitting correctly.

Spatter on the wire

An unprotected coil of wire quickly collects dust and other airborne contamination. If grinding is being performed in the vicinity, particles can become attached to the wire, severely interfering with the wire feed. Replace with clean wire and keep it protected with a cover. Make sure spare wire rolls are stored in a clean, dry place.

Coil brake incorrectly adjusted

Set the brake so that the coil immediately stops rotating as soon as welding is interrupted. If the brake is applied too hard it will cause the feed rolls to slip, resulting in uneven wire feed. If it is too loose, overrun of the wire will occur, causing wire tangles, inconsistent tension on the feed mechanism and irregular arc characteristics.

UNSTABLE ARC

Incorrect setting of voltage and/or current

Set the wire feed in relation to the arc voltage in such a way that the arc is stable and burns evenly. In spray arc welding, set the wire feed so that there are no short circuits and the filler metal is transferred in a spray across the arc. Find the cause of the interference and correct it. (See ERRATIC WIRE FEED above)

Problems in wire feeding: worn current tip

When the internal diameter of the current tip becomes worn from the passage of wire through it, the wire may no longer stay in continuous electrical contact with the tip. This results in an unstable arc and an increase in spatter. Paint, mill scale, silicon scale, rust or flux deposits from previous weld runs may form an insulating layer causing an unstable arc. Clean the surfaces to be welded.

Impurities on the base metal

Securely attach the ground cable as close to the point of welding as possible on the workpiece. Clean the surfaces thoroughly to ensure good contact.

Poor contact between ground cable and workpiece or loose power connection

Check to insure the welding power connection on the power source is tight, the and workpiece. Connection on the wire feeder is tight, the connection to the adaptor block is tight, Loose power connection and the connection of the gun to the adaptor block is tight.

Stick-out too long

Adjust the current tip to work distance to a minimum of 3/8" for short arc welding. A more precise distance is 15 times the wire diameter.

TROUBLESHOOTING: GENERAL GUIDE

Problems/Causes

Possible Solutions

AIR-COOLED GUN RUNNING TOO HOT

Poor ground

Inspect ground cable for loose connections, fraying and cuts. Correct any problem areas found. Clean clamping area to insure good contact. Securely attach the ground cable to the workpiece, as close as possible to the point of welding. Make sure there is a good connection to the welding power source.

Loose power connection

Check to make sure the power connection on the power source is tight, the connection on the wire feeder is tight, the connection to the adaptor block is tight, and the connection of the gun to the adaptor block is tight.

Consumable items loose or worn

Remove nozzle from gun and inspect current tip, collet nut (tip holder) and spatter disc (gas diffuser) for wear and tightness; replace or tighten as necessary.

Capacity of gun being exceeded

Note complete weld parameters, including welding current (Amps), welding voltage, wire feed speed, type and size of wire, type of gas and flow rate of gas and consult your local Authorized D/F Machine Specialties Distributor or contact the factory.

Dirty connection

Remove torch and inspect parts for dirt build-up. Periodic cleaning is necessary.

TROUBLESHOOTING: POROSITY (SUMMARY)

NOTE: Most POROSITY is caused by gas problems, followed by base metal contamination.

Causes of Porosity

BASE METAL CONTAMINATION

Impurities on base metal

FILLER METAL CONTAMINATION

Impurities on filler metal (wire)

ATMOSPHERIC CONTAMINATION

Drafts, wind, fans, etc.

GAS MIXING APPARATUS

1. Too high a gas flow, causing turbulence, and/or sucking air at hose connections; creating the venturi effect at end of gas nozzle
2. Too low a gas flow, causing insufficient gas coverage
3. Damaged or kinked gas lines
4. Too high an oxygen content
5. Leaks in gas distribution system
6. Other impurities in gas - moisture, etc.
7. Inconsistent gas flow (cfh) at the torch connection

GAS TURBULENCE

1. Excessive spatter build-up in gas nozzle and on current tip
2. Nozzle damage, causing uneven gas coverage
3. Torch gas ports clogged or deformed
4. Super-heated nozzle, causing shielding gas to expand rapidly and create return effect at end of nozzle
5. Gas diffuser/nozzle insulator missing
6. Too high a gas flow causing the venturi effect

WELDING PARAMETERS, ETC.

1. Too long a wire stick-out; gas nozzle too far from weld puddle
2. Bad torch position - too sharp a torch incline causing the venturi effect at the end of the nozzle leading to atmospheric contamination
3. Excessively wide weld pool for nozzle I.D.
4. Arc voltage too high
5. Too high a travel speed

Possible Solutions

- a. Remove contamination; clean surfaces
 - b. Use of specific wire/gas mix for specific types of impurities
-
- a. Replace wire
 - b. Install wire-cleaning system
 - c. Prevent industrial dust/dirt/grit from contaminating wire during storage or use
 - d. Prevent build-up of aluminum oxide on exposed aluminum wire surface by using up quickly
 - e. Remove wire from wire drive unit and store in a sealed plastic bag when not in use for long periods
-
- a. Protect weld from drafts (curtains/screens)
 - b. Use tapered or bottleneck gas nozzles when drafts cannot be avoided
-
- 1a. Reduce gas flow
 - 1b. Tighten all hose connection points
 2. Increase gas flow
 3. Repair or replace
 4. Adjust mixer
 5. Repair leaks
 6. Overhaul system; fit filters and/or dryers
 7. Regulate pressure into flow meter for consistent cfh delivery of gas
-
1. Clean nozzle and tip regularly; spray with anti-spatter fluid
 2. Replace nozzle
 3. Clean or replace
 4. Check duty cycle rating of torch
 5. Replace
 6. Reduce gas flow
-
1. Use longer nozzle or adjust stick-out (3/8" minimum or 15 times wire diameter)
 2. Correct torch angle
 3. Width of the weld pool should be 1.3 times the nozzle I.D.; use suitable wider gas nozzle
 4. Reduce voltage
 5. Reduce speed

TROUBLESHOOTING: SPATTER

Problems/Causes

SPATTER

Too fast or too slow wire feed for the arc voltage

Too long an arc

Damaged current tip

Inclination of welding gun too great

Faulty power source

Incorrect start

Incorrect pulse parameters

Uneven wire feed

Impurities on the base metal

Poor ground contact

Too long stick-out (short-arc welding)

Incorrect polarity

Possible Solutions

Set the wire feed rate and voltage in accordance with good welding practices as recommended by a qualified welding engineer.

Adjust the wire feed and voltage so that the arc is in accordance with good welding practice for the joint to be welded. The distance from the current tip to the workpiece should be 15 times the welding wire diameter. If the arc is too long there will be spatter, usually in the direction of the weld.

If the current tip becomes worn the welding wire will not be in constant contact with the tip and the arc will become unstable. A current tip contaminated with spatter will cause uneven wire feed resulting in further spatter.

The angle of the gas nozzle relative to the workpiece should be between 45 and 90 degrees. If the angle is too small, the wire runs parallel to the weld pool, resulting in spatter in the direction of the welding.

Have the power source checked for faulty conditions such as broken wires and faulty contacts.

A great deal of spatter occurs if the stick-out is too great and if the welding gun is held too far from the workpiece when striking the arc. Try to start with as short a stick-out as possible and with the welding gun as close to the starting point as possible. If a large ball end is formed on the end of the welding wire, remove it by cutting the wire with sharp wire cutters. It is helpful if the wire is cut to a point. Always remove the ball end before striking an aluminum arc. Check the welding ground connection.

Check the user manual for your power supply or consult a qualified welding engineer.

Uneven wire feed gives rise to heavy spatter. Find the cause of the disturbance and correct the condition before proceeding.

Paint, mill scale, rust and other contamination on the base metal form an insulating layer causing an unstable arc that results in heavy spatter. Clean the surfaces to be welded.

Inspect ground cable for loose connections, fraying and cuts. Correct any problem areas found and attach the ground cable directly to the workpiece after having cleaned the contact surface first. **POOR GROUND CONTACT IS THE MOST COMMON CAUSE OF UNSTABLE MIG WELDING CONDITIONS.**

The stick-out should be 15 times the diameter of the wire electrode being used. With increasing stick-out, the current is reduced and the arc voltage rises, giving a longer unstable arc and increased spatter.

Check for correct polarity. Follow the electrode manufacturer's recommendations.

D/F MACHINE SPECIALTIES, INC.

MIG & TIG Welding Products, Consumables & Accessories

WARRANTY

This Equipment is sold by D/F MACHINE SPECIALTIES, Incorporated, under the warranty set forth in the following paragraph. Such warranty is extended only to the buyer who purchases the equipment directly from D/F or its authorized distributor as new merchandise.

The barrel and cable assemblies are warranted by D/F to be free from manufacturing defects for 90 days after delivery by D/F, provided that the equipment is properly operated under conditions of normal use and that regular periodic maintenance and service is performed. Expendable parts are not warranted for any specific time. Expendable parts referred to herein would be the nozzles, current tips, spatter discs, insulators, casing liners, and wire inlets. D/F's sole obligation under this warranty is limited to making replacement at its manufacturing facility for barrel assemblies which are returned to it with transportation charges prepaid, and upon D/F's examination have been found to be so defective.

Genuine D/F MACHINE SPECIALTIES, Inc. Parts, Accessories, and Consumables must be used for safety and performance reasons. The use of anything other than genuine D/F MACHINE SPECIALTIES, Inc. Parts, Accessories, or Consumables will void this Warranty. All units returned for warranty repair are subject to Warranty Inspection. Warranty and repair work shall not apply to goods that have been altered or repaired, have been subject to misuse or used while any parts are loose, broken, or damaged, or used with other than original D/F® parts, consumables, or accessories which may affect performance and safety.



Rev. 150603-3

D/F MACHINE SPECIALTIES, INC.

1750 Howard Drive

North Mankato, MN 56003

Phone: (507) 625-6200

Fax: (507) 625-6203

www.dfmachinespecialties.com